



(12) **EUROPEAN PATENT SPECIFICATION**

(45) Date of publication and mention of the grant of the patent: 12.07.2000 Bulletin 2000/28
(51) Int. Cl. 7: G06K 19/16
(21) Application number: 93302213.9
(22) Date of filing: 23.03.1993

(54) **System Identifying the authenticity of an article**
Gegenstandsechtheit-Erkennungssystem
Système d'identification d'authenticité d'un article

(84) Designated Contracting States:
DE FR GB
(30) Priority: 28.04.1992 JP 13778692
(43) Date of publication of application:
03.11.1993 Bulletin 1993/44
(73) Proprietor: NHK SPRING CO.LTD.
Yokohama-shi, Kanagawa-ken (JP)
(72) Inventors:
• Hoshino, Hidekazu
Yokohama-shi, Kanagawa-ken (JP)

• Haga, Hidemi
Yokohama-shi, Kanagawa-ken (JP)
(74) Representative:
Browne, Robin Forsythe, Dr.
Urquhart-Dykes & Lord
Tower House
Merrion Way
Leeds LS2 8PA West Yorkshire (GB)
(56) References cited:
WO-A-86/05300

EP 0 568 185 B1

Note: Within nine months from the publication of the mention of the grant of the European patent, any person may give notice to the European Patent Office of opposition to the European patent granted. Notice of opposition shall be filed in a written reasoned statement. It shall not be deemed to have been filed until the opposition fee has been paid. (Art. 99(1) European Patent Convention).

Description

TECHNICAL FIELD

[0001] The present invention relates to an identification system for identifying the authenticity of an article.

BACKGROUND OF THE INVENTION

[0002] Conventionally, as means for identifying the authenticity of such articles as information storage cards including magnetic cards, stocks and bonds, tickets and commercial goods, a system of affixing a hologram marking, which is difficult to forge, on the article to be identified as an identification seal was proposed, for instance, in Japanese utility model laid-open publication No. 61-182580. As such identification seals are intended to be visually identified, they are normally affixed to the parts of articles to be identified which are easily noticeable from outside. Therefore, because designing of the external appearance of an article must take into account the position, shape and color of the identification seal that is going to be affixed thereto, freedom of design can be severely hampered, and in some cases the identification seal may destroy the balance in the design to such an extent that the appearance of the article may be severely impaired.

[0003] In Japanese patent laid-open publication No. 3-71383 filed by the applicant of this application, it was proposed to provide, on the surface of an article, a hologram region serving as an identification seal having a diffractive property unique to the article. In Japanese patent application No. 3-259636 (not yet published) filed by the same applicant and directed to an invention using the above-mentioned structure, an identification region made of a material which reflects, with a unique diffractive property, only the light having a prescribed wavelength, for instance light in the infrared band, which is not in the range of visible light, is affixed to such articles as information storage cards, stocks and bonds and tickets so that the identification region is normally transparent, but can be optically identified by using detecting light having the prescribed wavelength. According to this structure, the authenticity of the article can be identified with high accuracy, the forgery of the identification region is made more difficult, and the freedom in the design of the article is not in any way hampered.

[0004] However, in reality, it is difficult to obtain a layer which reflects only the light of a certain wavelength to a high degree, and the light to be reflected may well partly penetrate the layer and may be reflected by the surface of the article itself. In particular, when the surface of the article is metallic, and has a high reflective coefficient, the light reflected by the surface of the article may reach the light receiving region of the identification system along with the light reflected by the identification region whereby an erroneous detection

may be resulted, and an authentic article may not be identified as such.

[0005] WO-A-86/05300 discloses a security device in which a thick film hologram includes at least one discrete reflective region which when illuminated reflects strongly in a specific direction. A reader incorporates a light source and one or more photodiode detectors arranged to detect directional reflections to discriminate against non-holographic reflections and to perform a security function on detection of appropriate reflections.

BRIEF SUMMARY OF THE INVENTION

[0006] In view of such problems of the prior art, a primary object of the present invention is to provide an article identification system which allows the authenticity of an article to be identified reliably without disturbing the external appearance of the article.

[0007] A second object of the present invention is to provide an article identification system which allows the authenticity of an article to be identified reliably without restricting the design of the article.

[0008] A third object of the present invention is to provide an article identification system which uses an identification region to be placed on an article to be identified, but this identification region is so inconspicuous that it would not attract the attention of the potential forger, and the possibility of the identification region to be counterfeited is reduced.

[0009] According to the present invention, there is provided an article identification system for identifying the authenticity of an article, comprising:

identification means including at least a first layer, consisting of hologram or diffraction grating, having a reflective property for substantially reflecting light having a prescribed wavelength;

light emitting means for impinging light emitted therefrom onto said identification means, said light having the prescribed wavelength;

light detecting means for detecting light reflected by said identification means, said light detecting means being provided with a filter which selectively allows transmission of light having a certain polarisation direction; and

control means for evaluating light detected by said light detecting means and determining the authenticity of said article associated with said identification means;

characterised in that:

the light emitted from said light emitting means has a wavelength outside a visible range, and is linearly polarised in a prescribed direction, said first layer being capable of reflecting said light from said light emitting means but substantially transparent to visible light; and

said identification means includes an underlying second layer which is at least semi-transparent and

provided with such a polarisation plane rotating property that light which has emitted from said light emitting means, passed through said first and second layers and been reflected by a third layer or a surface of said article itself onto said light detecting means is substantially prevented from passing through said filter.

[0010] Preferably, the second layer has such polarisation plane rotating property that polarised light which passed through said second layer twice has a polarisation direction rotated by approximately 90°, and said filter provided on said light detecting means is so oriented as to shut-off said light which has had a polarisation direction thereof rotated by 90° by said second layer.

[0011] Therefore, the light which has passed through the reflecting layer and reflected by the surface of the article itself or an underlying layer is prevented from reaching the light detecting device so that spurious noises which may disturb the identification process can be effectively eliminated. To effectively eliminate the influences of the component of light which has passed through the reflecting layer, and reduce spurious noises due to such a component of light, the second layer preferably has such a polarisation plane rotating property that polarised light which has passed through the second layer twice has a polarisation direction rotated by approximately 90 degrees while the filter provided on the light detecting means is so oriented as to shut off the light which has had a polarisation direction thereof rotated by 90 degrees by the second layer.

[0012] The wavelength of the light emitted from the light emitting means is outside a visible light band, and the first layer reflects the light from the light emitting means but is substantially transparent to visible light. Thus, the identification region is hardly visible to human eyes, and this not only discourages an attempt to counterfeit the identification region but also would not affect the external appearance of the article.

BRIEF DESCRIPTION OF THE DRAWINGS

[0013] Now the present invention is described in the following with reference to the appended drawings, in which:

Figure 1 is a perspective view of a card and the identification system for identifying the authenticity of the card according to the present invention;

Figure 2 is a side sectional view of a light emitting device and a light receiving device used in the system illustrated in Figure 1;

Figure 3 is a plan view of the light emitting device and the light receiving device;

Figure 4 is an enlarged sectional view of the identification region;

Figure 5 is a graph showing the relationship between the wavelength of the illuminating light and

the transmittance of the light reflecting layer, and Figure 6 is a side sectional view illustrating the operation of the present embodiment.

DETAILED DESCRIPTION OF THE PREFERRED EMBODIMENTS

[0014] In the preferred embodiment illustrated in Figures 1 through 6, a magnetic card 1 is given as an example of article the authenticity of which is desired to be identified according to the present invention. As illustrated in Figure 1, a magnetic stripe 2 extends longitudinally on a surface 1a of the card 1. Further, an identification seal 3 serving as a light reflecting region having a unique diffractive property as described hereinafter is provided on the surface 1a.

[0015] Meanwhile, a magnetic head 4 is provided inside a reader/writer for the card 1 so as to oppose the magnetic stripe 2 as the card 1 is conveyed in the reader/writer by a conveying unit not shown in the drawing. A light emitting/receiving unit 5 is also provided in the reader/writer so as to oppose the identification seal 3 as the card 1 is conveyed therein. This light emitting/receiving unit 5 comprises a light emitting device 6 for impinging illuminating laser light having the wavelength of 780 nm and linearly polarized in a certain direction upon the identification seal 3 provided on the surface 1a of the card 1, and an annular light receiving device 8 surrounding this light emitting device 6 (Figure 3). The surface of the light receiving device 8 is covered by a polarization filter 7 which allows transmission of only the light linearly polarized in the above mentioned direction (Figure 2). The light emitting device 6 directly opposes the identification seal 3 when the card 1 is conveyed to a prescribed position inside the reader/writer. The light receiving device 8 consists of a multi-segment photodiode which is divided by radial lines into eight segments 8a through 8h each capable of individually detecting light. The light receiving device 8 is connected to a determination unit 9 which comprises a CPU, memory and an I/F circuit of known type, and determines the authenticity of the card 1 as illustrated in Figure 1.

[0016] As best illustrated in Figure 4, the identification region 3 comprises a hologram layer 10 consisting of a hologram forming layer 10a and an underlying light reflecting layer 10b, an adhesive layer 11 layered below the hologram layer 10 and serving also as a cushion layer, and a film-like polarization plane rotating layer 12 provided between the adhesive layer 11 and the surface 1a of the card 1. The surface of the hologram layer 10 is covered by a protective layer 13.

[0017] The hologram forming layer 10a allows transmission of light while the light reflecting layer 10b comprises mutually interleaved layers of sodium hexafluoroaluminate (Na_2AlF_6) having a relatively small index of refraction and zinc sulphate (ZnS) having a relatively large index of refraction so that the light reflecting layer 10b demonstrates a high transmittance (approximately

100%) for illuminating light in the visible light band (380 to 700 nm in wavelength) and a low transmittance for illuminating light in the infrared light band (700 nm or longer in wavelength). Therefore, this hologram layer is essentially invisible to human eyes, and has such a diffractive property that infrared light impinged squarely thereon is diffracted and reflected onto a pair of segments diagonally opposing each other on either side of the light emitting device 6.

[0018] On the other hand, the polarization plane rotating layer 12 is made by extending polycarbonate resin having a relatively pronounced double refractive property. The thickness of the polarization plane rotating layer 12 is determined in such a manner that one quarter of the wavelength of the laser light emitted from the light emitting device 6 corresponds to the amount of double refraction of this layer. Therefore, as the component of the incident laser light which has transmitted through the light reflecting layer 10b is passed through this polarization plane rotating layer 12, reflected by the surface 1a of the card 1, and again passed through the polarization plane rotating layer 12, its plane of polarization is rotated by 90 degrees.

[0019] When actually identifying the authenticity of the card 1, the card 1 is conveyed until the identification seal 3 squarely opposes the light emitting device 6 of the light emitting/receiving unit 5. Then, illuminating light having the wavelength of 780 nm and linearly polarized in the prescribed direction is impinged from the light emitting device 6 onto the identification seal 3. The light diffracted and reflected by the identification seal 3 is transmitted through the polarization filter 7 before it is captured by specific segments 8a through 8h of the light receiving device 8, and the authenticity of the card 1 is identified according to the intensity of the light received by them. In this case, as the light which has passed through the light reflecting layer 10b travels both ways through the polarization plane rotating layer 12 before it reaches the polarization filter 7, its plane of polarization is rotated by 90 degrees. Therefore, the light is able to reach the polarization filter 7, but cannot pass through the polarization filter 7 nor reach the light receiving device 8. Thus, even when the surface 1a of the card 1 has a high coefficient of reflection, there is substantially no possibility of causing any erroneous detection (Figure 6).

[0020] Therefore, even when a potential forger has obtained this card 1 with illicit intention, because the identification seal is hardly visible with naked eyes and its position is therefore hard to identify, and because the analysis of the reflective property of the hologram and the forgery of the hologram are both technically difficult, and prohibitively expensive, it is practically impossible for him to commit the forgery of the card.

[0021] It is obvious that the present invention is not limited by the above embodiment but can be implemented in various other forms. For instance, the hologram was prepared in such a manner that the

illuminating light was diffracted onto two of the segments 8a through 8h of the light receiving device 8, but may also be prepared in such a manner that the illuminating light is diffracted onto four or more of the segments 8a through 8h of the light receiving device 8.

[0022] In the above described embodiment, the identification region was affixed to a magnetic card 1 serving as an information storage card, but similar results can be achieved even when they are affixed to checks, promissory notes, gift certificates, and other monetary papers, and general commercial goods or the packages thereof. In this case, by placing a mask having an opening in a prescribed position over the card 1, and selecting the position of the opening so as to correspond to the identification seal affixed to the card, it is possible to identify the identification seal by using a hand-carried hand scanner. When the monetary papers are desired to be identified, although they tend to deform very easily, because the properties of hologram and diffraction grating are not substantially affected even when there is an angular deformation of, for instance, five degrees, no significant problems are created. For this reason, such identification seals can be affixed to curved parts of goods such as tennis racket handles, and can be used satisfactorily for the purpose of identifying the authenticity of such goods.

[0023] Further, in the above described embodiment, hologram was used for the identification mark of the identification seal affixed to the card 1, similar results can be obtained when diffraction grating is used instead.

[0024] Thus, according to the system for identifying an article of the present invention, by providing light emitting means for emitting light having a prescribed wavelength and linearly polarized in a prescribed direction, an identification region defined on the article, the identification region including a light reflecting layer which is adapted to transmit visible light and reflect light of wavelength other than those of visible light with a certain reflective directivity property, and a polarization plane rotating layer made of optically anisotropic material which rotates linearly polarized light of the certain wavelength by double refraction, light receiving means for receiving the light reflected by the light reflecting layer, and a polarization filter for allowing transmission of only the rotated linearly polarized light placed on a light receiving surface of the light receiving means, the visible light is not reflected by the light reflecting layer and the light reflecting layer is therefore made transparent so that the identification system would not affect the design of the article, and the freedom of design is substantially improved. Further, the light reflected by the surface of the article which tends to give rise to noises for the process of the identification is thereby improved. Thus, the present invention offers a significant improvement over the prior art.

Claims

1. An article identification system for identifying the authenticity of an article, comprising:

identification means (3) including at least a first layer (10), consisting of hologram or diffraction grating, having a reflective property for substantially reflecting light having a prescribed wavelength;

light emitting means (6) for impinging light emitted therefrom onto said identification means (3), said light having the prescribed wavelength;

light detecting means (8) for detecting light reflected by said identification means (3), said light detecting means (8) being provided with a filter (7) which selectively allows transmission of light having a certain polarisation direction; and

control means for evaluating light detected by said light detecting means (8) and determining the authenticity of said article associated with said identification means (3);

characterised in that:

the light emitted from said light emitting means (6) has a wavelength outside a visible range, and is linearly polarised in a prescribed direction, said first layer (10) being substantially transparent to visible light; and

said identification means (3) includes an underlying second layer (12) which is at least semi-transparent and provided with such a polarisation plane rotating property that light which has emitted from said light emitting means (6), passed through said first (10) and second (12) layers and been reflected by a third layer or a surface of said article itself onto said light detecting means (8) is substantially prevented from passing through said filter (7).

2. An article identification system according to claim 1, wherein said second layer (12) has such polarisation plane rotating property that polarised light which passed through said second layer twice has a polarisation direction rotated by approximately 90°, and said filter (7) provided on said light detecting means (8) is so oriented as to shut-off said light which has had a polarisation direction thereof rotated by 90° by said second layer.

Patentansprüche

1. Gegenstands-Identifikationssystem zur Identifizierung der Echtheit eines Gegenstandes, mit

einer Identifikationseinrichtung (3) mit wenigstens einer ersten Schicht (10), die aus einem

Hologramm- oder Beugungsgitter besteht, welches eine Reflexionseigenschaft zum im wesentlichen Reflektieren von Licht mit einer festgelegten Wellenlänge aufweist;

einer Lichtausstrahlungsvorrichtung (6) zum Beaufschlagen der Identifikationseinrichtung (3) mit dem davon ausgesendeten Licht, wobei das Licht die festgelegte Wellenlänge hat;

einer Lichterfassungsvorrichtung (8) zum Erfassen von durch die Identifikationseinrichtung (3) reflektiertem Licht, wobei die Lichterfassungsvorrichtung (8) mit einem Filter (7) versehen ist, der selektiv den Durchlaß von Licht mit einer bestimmten Polarisationsrichtung erlaubt; und

einer Steuereinrichtung zum Auswerten von durch die Lichterfassungsvorrichtung (8) erfaßtem Licht und Bestimmen der Echtheit des der Identifikationseinrichtung (3) zugeordneten Gegenstandes,

dadurch gekennzeichnet,

daß das von der Lichtausstrahlungsvorrichtung (6) ausgesendete Licht eine Wellenlänge außerhalb des sichtbaren Bereichs aufweist und in einer festgelegten Richtung linear polarisiert ist, wobei die erste Schicht (10) im wesentlichen für sichtbares Licht durchlässig ist; und

daß die Identifikationseinrichtung (3) eine darunter liegende zweite Schicht (12) enthält, die wenigstens halbdurchlässig ist und mit einer solchen Eigenschaft zur Drehung der Polarisationssebene versehen ist, daß Licht, welches von der Lichtausstrahlungsvorrichtung (6) ausgesendet wurde, durch die erste (10) und die zweite (12) Schicht lief und durch eine dritte Schicht oder eine Oberfläche des Gegenstandes selbst auf die Lichterfassungsvorrichtung (8) reflektiert wurde, im wesentlichen am Durchlaufen des Filters (7) gehindert wird.

2. Gegenstands-Identifikationssystem nach Anspruch 1,

dadurch gekennzeichnet,

daß die zweite Schicht (12) eine solche Eigenschaft zur Drehung der Polarisationssebene aufweist, daß polarisiertes Licht, welches zweimal durch die zweite Schicht gelaufen ist, eine um etwa 90° gedrehte Polarisationsrichtung besitzt, und daß der auf der Lichterfassungsvorrichtung (8) vorgesehene Filter (7) so orientiert ist, daß er das Licht, welches eine um 90° durch die zweite Schicht gedrehte Polarisationsrichtung besitzt, sperrt.

55 Revendications

1. Système d'identification d'objet destiné à identifier l'authenticité d'un objet, comprenant :

des moyens d'identification (3) comprenant au moins une première couche (10), constituée d'un hologramme ou d'un réseau de diffraction, présentant une propriété de réflexion afin de réfléchir sensiblement la lumière ayant une longueur d'onde prescrite ;

des moyens d'émission de lumière (6), afin que la lumière émise par eux heurte les moyens d'identification (3), cette lumière ayant la longueur d'onde prescrite ;

des moyens de détection de lumière (8) destinés à détecter la lumière réfléchie par les moyens d'identification (3), ces moyens de détection de lumière (8) étant équipés d'un filtre (7) qui permet sélectivement la transmission de lumière ayant une certaine direction de polarisation ; et

des moyens de commande permettant d'évaluer la lumière détectée par les moyens de détection de lumière (8) et de déterminer l'authenticité de l'objet associé aux moyens d'identification (3) ;

caractérisé en ce que :

la lumière émise par les moyens d'émission de lumière (6) a une longueur d'onde située en dehors d'un spectre de lumière visible, et est polarisée linéairement dans une direction prescrite, la première couche (10) étant sensiblement transparente à la lumière visible ; et

les moyens d'identification (3) comprennent une deuxième couche située dessous (12), qui est au moins semi-transparente et pourvue d'une propriété de pivotement du plan de polarisation telle que de la lumière ayant été émise par les moyens d'émission de lumière (6), ayant traversé les première (10) et deuxième (12) couches et ayant été réfléchie par une troisième couche, ou par une surface de l'objet proprement dit, sur les moyens de détection de lumière (8), est sensiblement empêchée de traverser le filtre (7).

2. Système d'identification d'objet selon la revendication 1, dans lequel la deuxième couche (12) présente une propriété de rotation du plan de polarisation telle que de la lumière polarisée ayant traversé deux fois la deuxième couche présente une direction de polarisation pivotée d'approximativement 90° , et le filtre (7) prévu sur les moyens de détection de lumière (8) est orienté de façon à arrêter la lumière dont la direction de polarisation a été pivotée de 90° par la deuxième couche.

Fig. 1

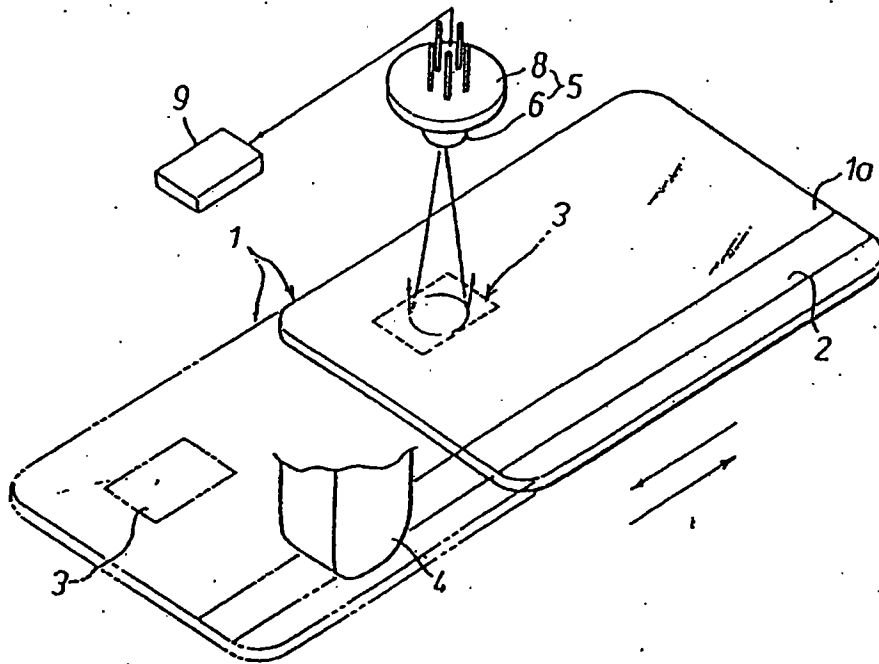

Fig. 2

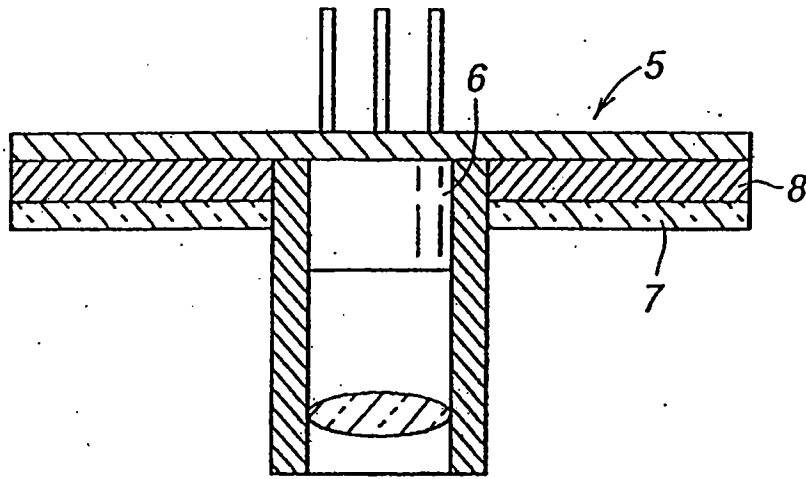

Fig. 3

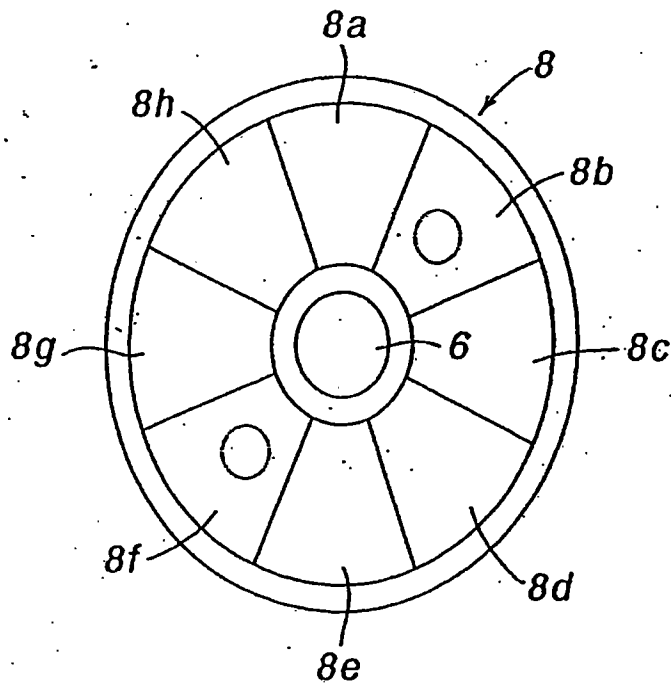

Fig. 4

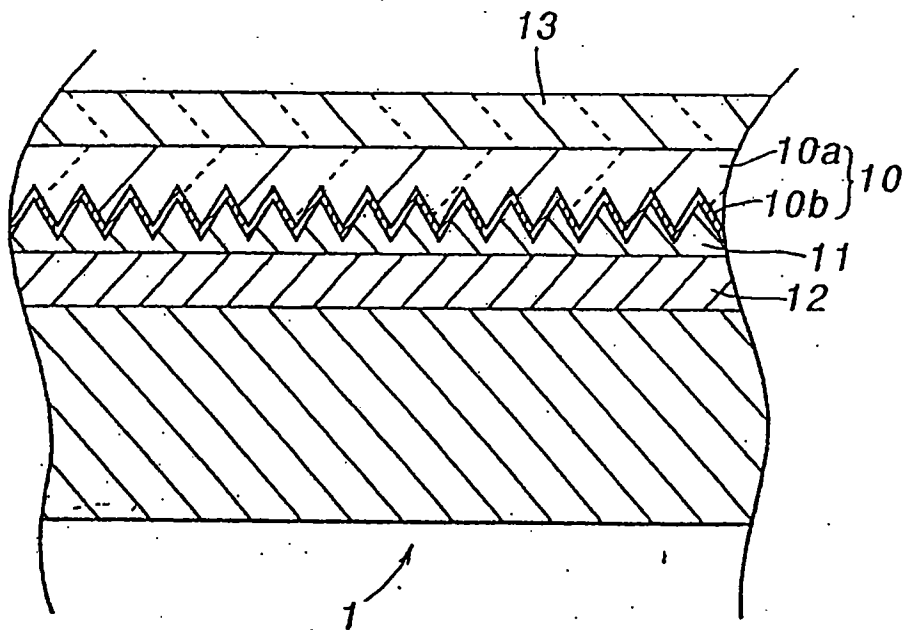

Fig. 5

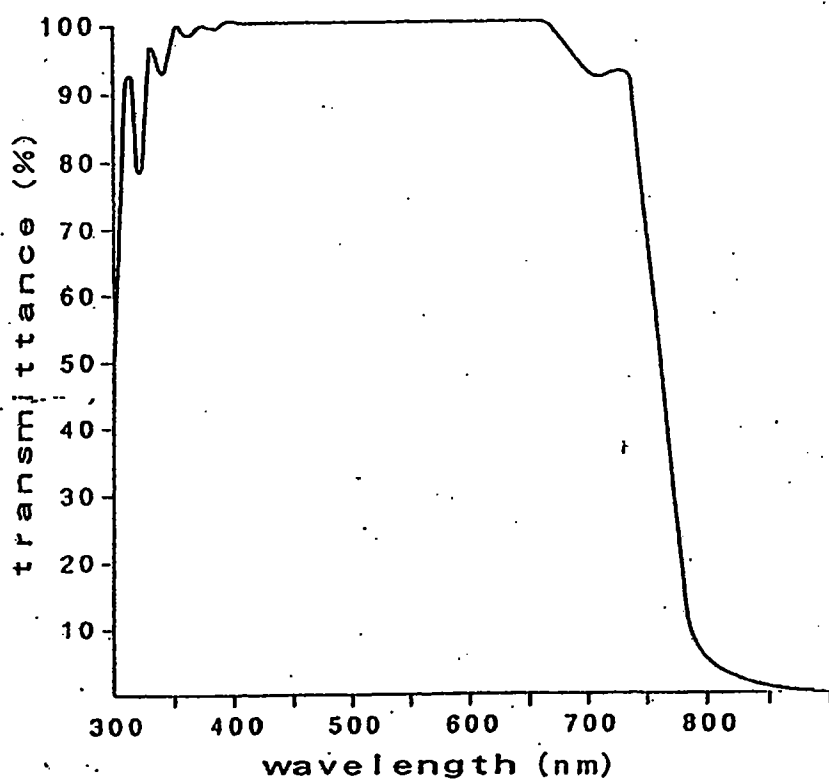

Fig. 6

